

014R9572

014R9572

HFC, HCFC, CFC

T: -50 → +80°C

PB/MWP		
SG	6 → 12	PB = 35 bar
SG	16s solder	PB = 35 bar
	16 flare	PB = 28 bar
SG	19 → 22	PB = 28 bar
SGR		PB = 35 bar

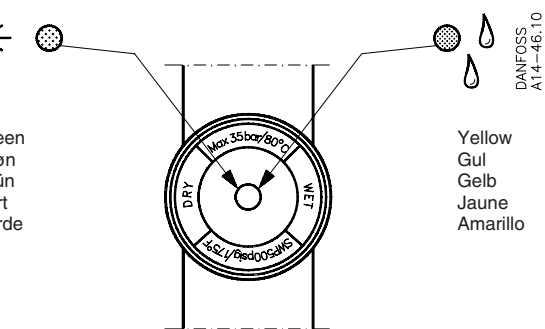
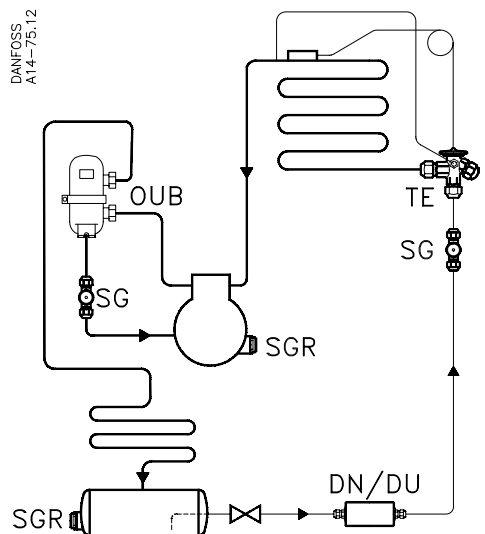

4198

DANFOSS A14-26.11

DANFOSS A14-66.12

DANFOSS A14-65.12

SG 6: W=14mm (9/16 in.)	SG 6: W=16mm (5/8 in.)
SG 10: W=19mm (3/4 in.)	SG 10: W=22mm (7/8 in.)
SG 12: W=22mm (7/8 in.)	SG 12: W=24mm (15/16 in.)
SG 16: W=27mm (1 1/16 in.)	SG 16: W=27mm (1 1/16 in.)
SG 19: W=32mm (1 1/4 in.)	SG 19: W=32mm (1 1/4 in.)

DANFOSS A14-47.13

DANFOSS A14-50.13

Max. 100Nm (72ft-lbs)

DANFOSS A14-67.11